

YL-203 Series

User Manual

BINDTec

Table of Contents

- 1.Product Description
- 2.Band Installation and Unpacking
- 3.Major Part
- 4.Operation & Temperature and Tension Control
- 5.Troubleshooting
- 6.Cleaning & Maintenance



Warning



- 1.Make sure that the rated AC voltage complies with the marked AC power beside the product before you plug the power cord in the power inlet.(110v/220v)
- 2.If you open the cover, you can be exposed to the high temperature and get burned. 
- 3.Do not keep the product in the wet and moist place in order to prevent the danger of fine or electrical damage. We request you to install the product in the safe place.
- 4.Make sure that the band is in the right direction.

1. Product Description

- Designed the machine to be used in the office and small space.
- Reduce the error to the minimum
- Installed the jam free mechanism

- * Band specification

 - Band width:8,10mm

 - Band thickness:0.4/0.7mm

- * Power supply : 110/220V 50/60Hz

- * Strapping speed : 7~25kgf

- * Welding method : Heat welding by heat plate

The type of the Semi-Automatic Strapping Machines are as below

YL-203



Table size : 405(W) X 325(D)mm

Product size : 651(W) X 325(D) X 221(H) mm

Net weight : 17kg

Power supply : AC 110/220V, 50/60Hz

YL-203S

Table size : 405(W) X 325(D) mm

Product size : 405(W) X 325(D) X 790(H) mm

Net weight : 30kg

Power supply : AC 110/220V, 50/60Hz



YL-203SII

Table size: 405(W) X 325(D) mm

Product size : 405(W) X 325(D) X 790(H) mm

Net weight : 34kg

Power supply : AC 110/220V, 50/60Hz



2. Band Installation and Unpacking

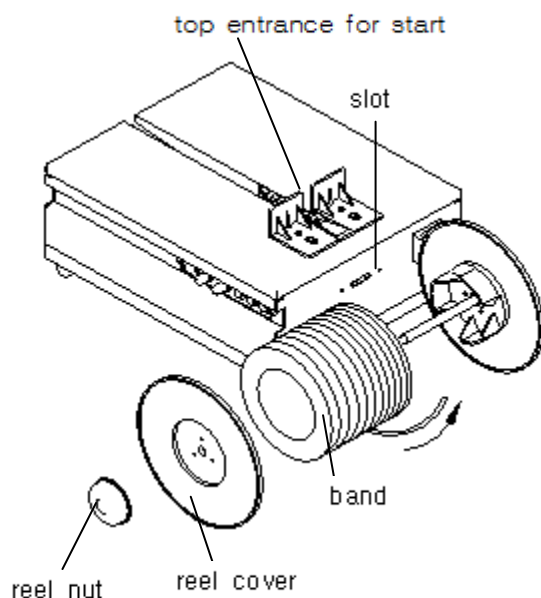

1. Installation

*First be sure that band is in correct direction and then insert the band into the reel guide.

*If the tip of band is much bent or damaged, cut it off by scissor.

2. Insertion

*Insert the band into the band slot slow while pressing the forward button.

*Release the switch after the insert of band.

Unpacking

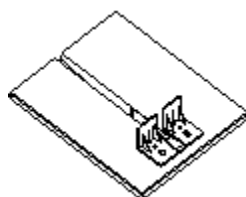

Top plate

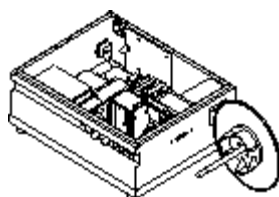

Main body

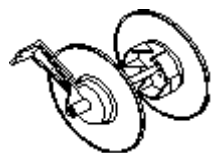

Reel set



Power cable



ppband



Manual

2.1 Band Installation and Unpacking (stand)

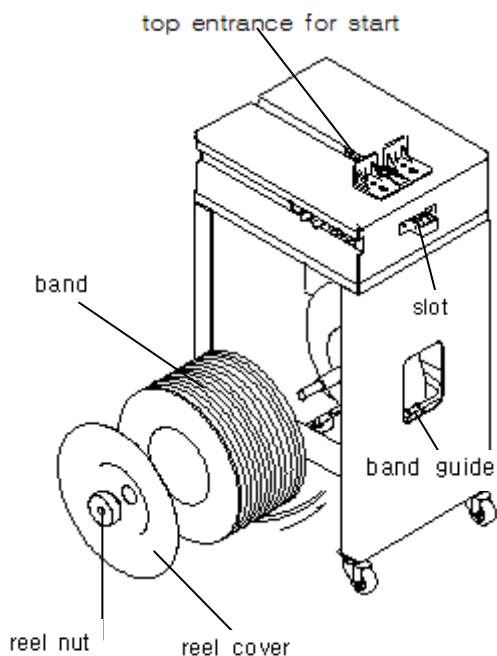

1. Installation

*First be sure that band is in correct direction and then insert the band into the reel guide.

*If the tip of band is much bent or damaged, cut it off by scissor.

2. Insertion

*Insert the band into the band slot slow while pressing the forward button.

*Release the switch after the insert of band.

Unpacking

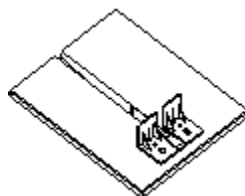

Top plate



Manual



Power cable

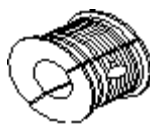

ppband

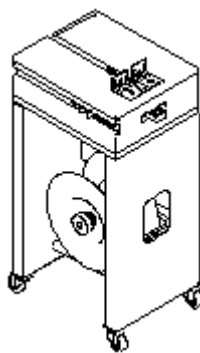

Main body

3. Major part

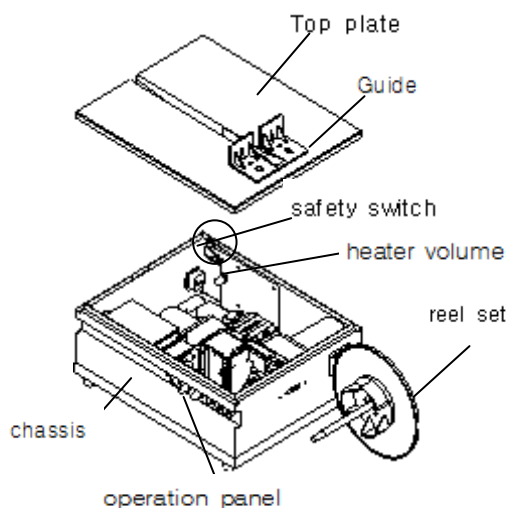

power inlet

Major part of the machine

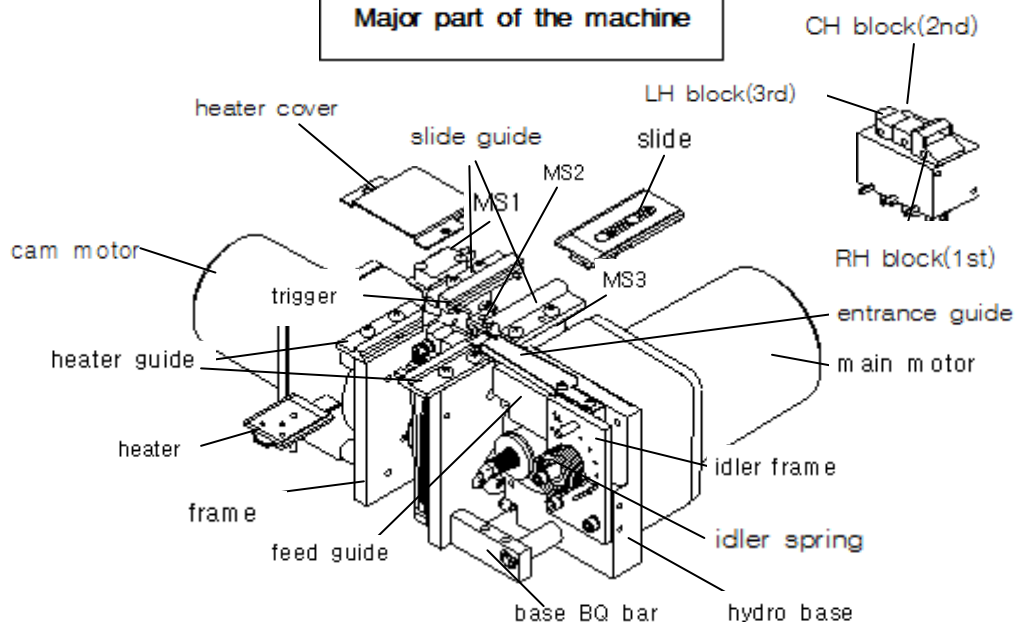

3.1 Major part (Stand)

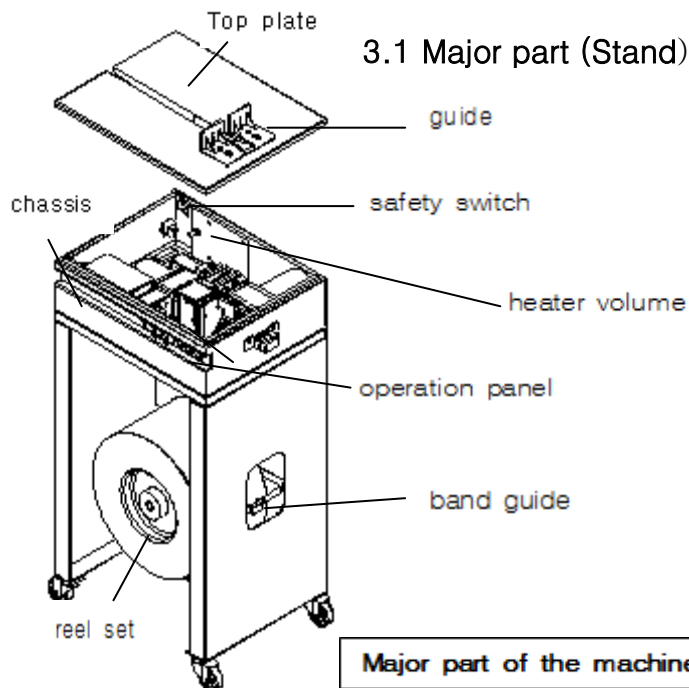

Major part of the machine

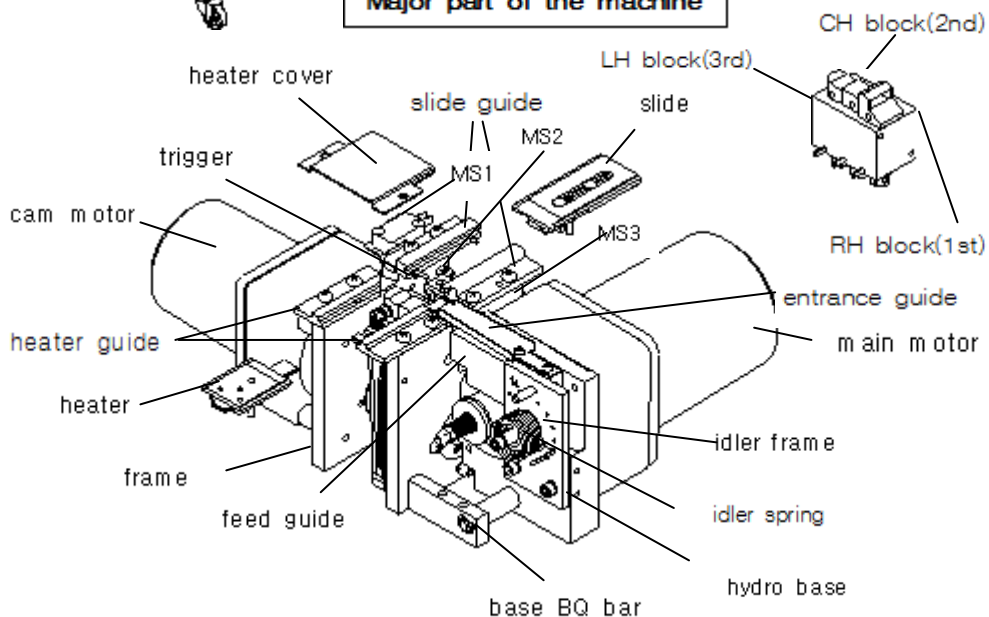

4. Operation

[GENERAL] After band installation place the package on the table and insert the band into start slot. Then the machine straps the package.

1. Turn the power switch on and preheat the machine about 1 minute.
2. Push the band into the slot slow while pressing the feed button.
Main roller and idle roller touch the band tightly and release it.
3. Put the package to the guide and insert the band into start slot.
4. If you insert the band into start slot, the machine straps the package and releases it as set by length volume.

Button Description

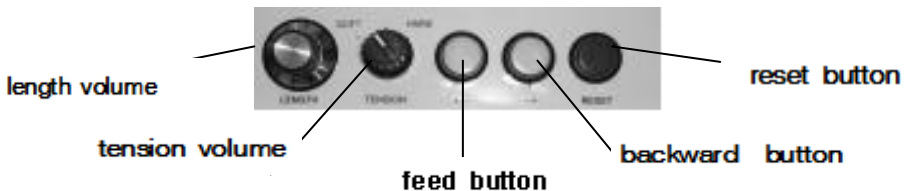

POWER switch: Turn the power switch on and preheat the machine about 1 minute before operation.

LENGTH volume: Adjust light volume to fit with package size. (If you turn length volume clock wise, band length will be adjusted longer.)

Tension volume: User can adjust tension volume for user's purpose. 4 stages are available from. (0.02, 0.04, 0.08, 0.16 second)

Feed button: Press this button and band will move forward slowly.

Backward button: Press this button and band will move backward slowly.

Adjustment of heater's temperature

If the bands are not weld properly, turn heater volume clockwise to make the temperature appropriate.
(output voltage:4.3~6.3V)



Recommended temperature : set switch volume at 6~7

Adjustment of Tension

Turn the tension control volume clockwise or counter-clockwise in the front panel to adjust tension.



Tension control switch has 4 selections and each pulls the band more or less by the set time.
(0.02, 0.04, 0.08, 0.16 a second)

Adjustment of Length

Turn the length volume in the front panel to the right or left to adjust length to be released.

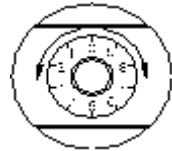

[Related drawings for trouble shooting]

idler roller(inside the machine)

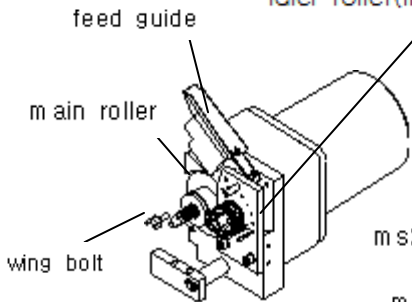

Hydro base part

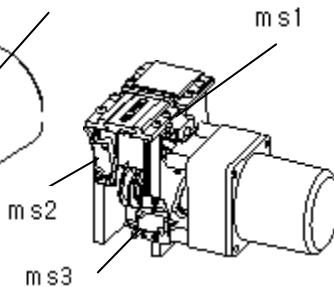

Frame part

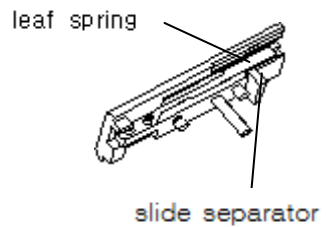

Slide part

5. Troubleshooting

STATE	Check and Management
1. Machine does not operate	<ul style="list-style-type: none"> *Check if the power cord is unplugged. (Check if the power is on) *Check if the voltage is correct. *Check if the safety switch operate. (Check if the top plate is properly closed)
2. Machine does not start	<ul style="list-style-type: none"> *Check if ms1 switch operates well. *Check if the leaf spring the beside slide. *Check if the trigger moves smoothly.
3. Band is not inserted properly	<ul style="list-style-type: none"> *Check if a lot of foreign materials are attached to idle rollers.
4. Strapping is not strong	<ul style="list-style-type: none"> *Check if the tension volume is set soft. *Clean the roller areas with methyl alcohol. *Check if there is something wrong with idle spring
5. Feed and back button do not work properly	<ul style="list-style-type: none"> *Check if the power cord unplugged. *Check if PCB or button has any problem.
6. Reset button does not work.	<ul style="list-style-type: none"> *Check power connection and PCB. *Check if the slide separator can't move with block.

6. Cleaning & Maintenance

*Cleaning of idle roller and main roller

Separate the wing bolt and raise up the feed guide. Remove band debris by using methyl alcohol.

Press the feed button and clean the surface of roller clearly.

*Cleaning of slide and heater

Disassemble the slide with heater and remove the band debris by using methyl alcohol.

Warning! Heater can be very hot.



*Clean the fan.(When smoke rises a lot)

Warning ! Be careful not to be exposed to burning damage, electrical damage, mechanical damage when amending or cleaning the machine.

Maintenance

*Do not keep the product in the wet and moist place

*Keep away from the place where ventilation is poor.

*Do not operate the machine on uneven floor.

*Plug the power cord in the indoor power inlet.

*Make sure that the rated AC voltage complies with the marked AC power of the product.

*Clean the machine regularly.

If you tried to troubleshoot the machine in vain, please contact your agent or headquarters with the following information.

1.Trouble 2.Model 3.Serial no. 4.Date of purchase

TEL : 82-31-734-2868 / FAX : 82-31-734-2869

PRODUCT WARRANTY

BINDTEC CO.,LTD warrants that it will repair and replace parts in accordance with the following terms if any defects in the material or workmanship of the binder occurs within 12 months from the day on which the user purchases it.

A purchase receipt or other evidence of the date of purchase must be shown in order to receive warranty services.

Warranty terms

This warranty is valid only while and if product is used and handled in a normal and reasonable manner in accordance with the User Manual and installation instructions.

Paid services

* Please carefully read the User Manual as you will be charged for any services requested except for product malfunctions guaranteed under the warranty.

* The product is not covered under warranty if damage or defects have occurred due to:

- customer misuse or unauthorized tampering or repairs;
- the replacement of parts other than those designated by BINDTEC CO.,LTD; or
- an act of God or the normal service life of any expendable parts being expired.

Model		Applicable bands	
Date of purchase		Serial no.	
Purchased at			



BINDTEC CO.,LTD.

#1011,177 SAGIMAKGOL-RO JUNGWON-GU
SEONGNAM-SI GYEONGGY-DO,KOREA

[TEL:+82-32-834-2868](tel:+82-32-834-2868)/[FEX:+82-31-734-2869](tel:+82-31-734-2869)

E-MAIL: sales@bindtec.kr

<http://www.bindtec.kr>