

# YL-200(300) Series

User Manual

***BIND*Tec**

# CONTENTS

**1. Safety Features Overview and Precaution**

**2. Product Introduction**

**3. Package Details**

**4. Assembly**

**5. Band Installation and Part Names**

**6. Operation**

**7. Temperature Control**

**8. Tension Control**

**9. Specifications**

**Warranty**

# 1 Safety Features Overview and Precaution



## For your safety

Please read this User Manual carefully before operating the binder.



## Maintenance requirements

1. Make sure that AC 220 V (110/220 V YL-300) power is supplied. Voltage fluctuation must be kept at a minimum.
2. High temperature and humidity or any other environmental conditions may render the unit nonoperational as the band may get jammed around the roller and so on.
3. Please clean the unit once a week. In particular, it is important to keep the roller clean.
4. Warranty will be void if the unit is tampered with or disassembled by anyone other than the designated service personnel.
5. Touching the heater when the unit is in operation or within 10 min of the machine's shutdown may cause burns and injuries.
6. Ensure that the power is turned off after using the unit.



Do not open the case to avoid electrocution.



Do not touch the cutter as the sharp blade may cause serious injuries.



Do not touch the heater as the high temperature may cause burns.

## 2 Product Introduction

### Automatic banding machine using paper or film band

#### [YL-200(300)]

The ease of installation and compactness of YL-200(300) allows for efficient use of office space.

YL-200(300) automatically, rapidly, and accurately replenishes the band, thereby eliminating any extra work.

It bands bills, small boxes, envelopes, pouches, etc., into a bundle.

It perform all packages without damage the products.

The YL-200(300) does not produce hazardous materials when using the band supplied by BINDTEC Co., Ltd

#### PRODUCTS

#### YL-200(300)



YL-200



YL-300



## 3 Package Details

Please ensure that the following components are in place.

1. Machine Body.....	1
2. Left and Right Band Guides.....	1 each
3. Binding Guide.....	1
4. Handle Bolts.....	2
5. Power Cable.....	1
6. User Manual.....	1
7. Test Roll.....	1
8. Return Spring.....	1

## 4 Assembly

- ① Top Plate
- ② Front Plate
- ③ Handle Bolts (M6)
- ④ Guide
- ⑤ Left Band Guide
- ⑥ Right Band Guide
- ⑦ Sub-Guide
- ⑧ Back Case

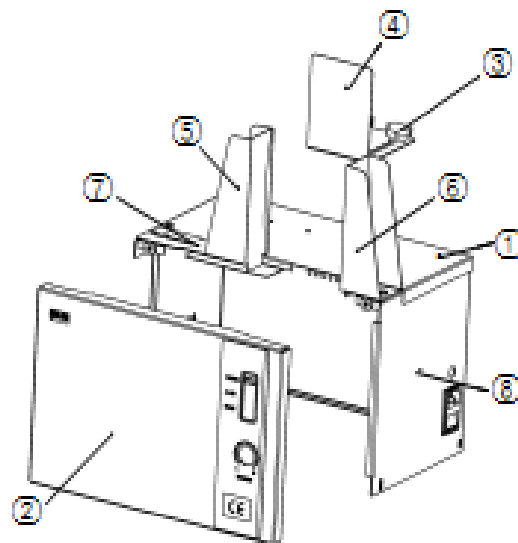

## 5

# Band Installation and Part Names

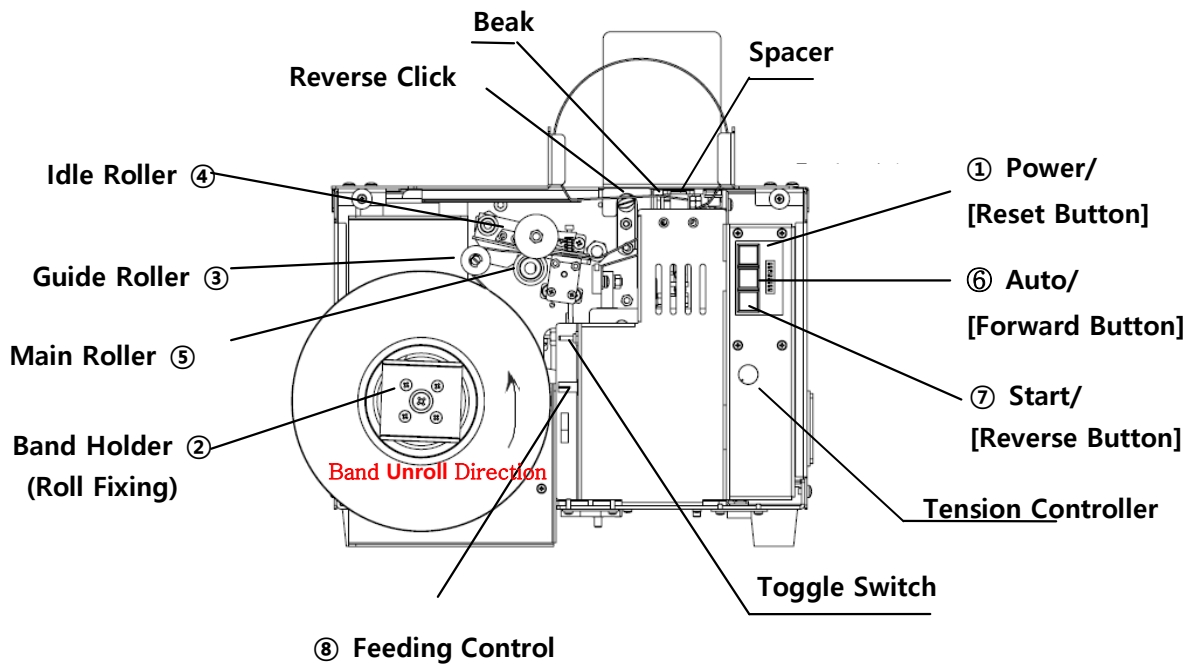

1. Open the Front Plate. The Toggle Switch can change the mode from "Feed" to "Start." The machine is in Inserting Band Mode if the switch is raised, and the lamp of the ① Power Button will start blinking. Then, put the band in the ② Band Holder, and make sure that the band unrolls in the right direction.

2. Hold the ends of the band, and push them through the ③ Guide Roller and then between the ④ Idle Roller and the ⑤ Main Roller.

Next, press the ⑥ Auto Button. The rollers will then turn to move the band forward. At this point, allow the band to roll in automatically as shown in the diagram.

3. Press the ⑦ Start Button if too much of the band is rolled in or a jam occurs around the rollers. The roller will then turn the other way to allow for the removal of the band.

4. Adjust the band using the ⑧ Feeding Control to change the length to be fed to the unit by turning the volume toward you or the opposite direction to increase or decrease the length, respectively.

5. Push down the toggle switch. It will convert to banding mode and the heater be heated.

The ⑦ Start Button will light up if the current temperature is far below the set value. On the other hand, the ⑥ Auto Button will light up if the temperature is only a little below the set value.

A blinking ① Power Button indicates that the current temperature has reached its set value. Moreover, pushing the ① Power Button will cut off any leftover band, and a new band should be placed in the machine (please hold the ends of the band during automatic cutting).

6. If the machine fails to insert the band or refit the band, press the ① Power Button hold it for 2 seconds, the band will be cut off and the machine will strap again.

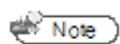

**Note** Please make sure that any creases on the band are cut off to avoid band jams.

## 6 Operation

### Preparation

1. Connect the power cable to the power inlet (the fuse hold and power switch are integrated).
2. Turn the power switch ON.
3. Feed the band to the unit as explained above.

### Manual Mode

1. The unit will be in Manual Mode after feeding the band.
2. Put the objects to be bundled inside the band ring (START button will start blinking once the Automatic Sensor detects the objects).
3. Press the START button and the banding operation will begin, and the band will be cut at the same time. After banding, band will be in place for the next bundle.

Automatic Sensor

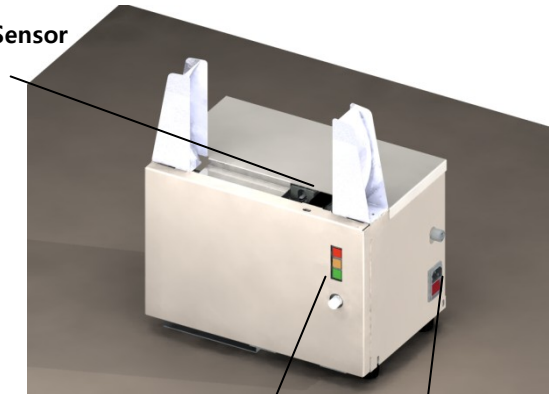

Power Switch

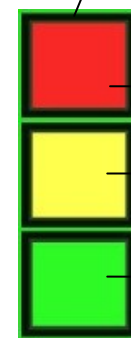

POWER

Reset Button

AUTO

Forward Button

START

Reverse Button

### Auto Mode

1. Press the AUTO button. The AUTO button will then light up, and the unit will switch to Automatic Mode.
2. Put the objects to be bundled inside the band ring.
3. The objects will be bundled automatically once detected by the sensor.

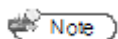

Bundling is performed without pushing the START button during automatic operation.



## 7 Temperature Control

Set the Dip Switches to ensure optimal temperature for the band's material and other conditions. As such, open the Front Plate to set the corresponding Dip Switch depending on your desired temperature.

### ● Example

Press switch no. 3 to set the temperature to 160°C.

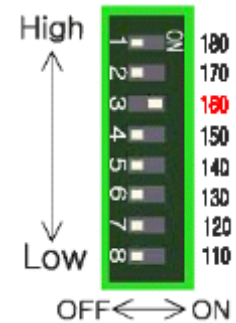

## 8 Tension Control

Use Tension Control to adjust strapping strength.

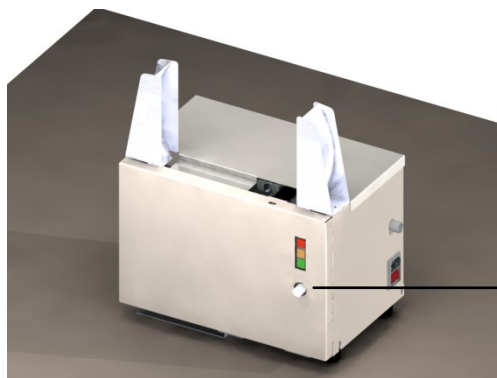

Tension Controller

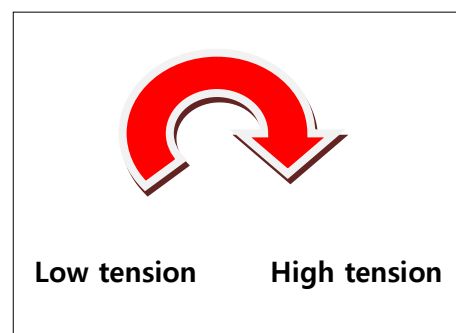

**Note** Tension is nonadjustable during binding.

## 9

# Specifications

Speed	Binding(paper/film)	20–21 cycles/min
Maximum Dimensions of the Bundle	YL-200 : 210 (W) x 170 (H) mm	
	YL-300 : 300 (W) × 170 (H) mm	
Power Supply	YL-200 : AC 220V 50/60Hz 1.6A	
	YL-300 : AC 110V, 220V 50/60Hz 1.6A	
Power Consumption	150W	
Heater	Plate type	
Band Width	YL-200 : paper 20, 30, 40 / film 20,30mm	
	YL-300 : paper 30, 40 / film 30mm	
Product Dimensions	YL-200 : 324 (W) × 210 (D) × 240 (H) mm	
	YL-300 : 410 (W) × 210 (D) × 240 (H) mm	
Weight	YL-200 : 17kg	
	YL-300 : 18kg	

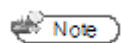

The band supplied by BINDTEC Co., Ltd., is recommended to maintain the machine's optimal performance.

# WARRANTY

**BINDTEC Co., Ltd.**, warrants that it will repair and replace parts under the following terms if any defects in the material or workmanship of the binder occur within 12 months from the day of purchase by the user.

A purchase receipt or other evidence for the date of purchase must be shown to receive warranty services.

## Warranty terms

This warranty is valid only while and if the product is used and handled in a normal and reasonable manner following the User Manual and installation instructions.

## Paid services

\*Please read the User Manual carefully, as you will be charged for any services requested except for product malfunctions guaranteed under the warranty.

\*The product is not covered by warranty if damages or defects have occurred because of:

- Customer misuse or unauthorized tampering or repairs;
- Use of parts other than those designated by **BINDTEC Co., Ltd.**; or
- An act of God or the expiration of the normal service lives of any expendable parts.

Model		Applicable Bands	
Date of Purchase		Serial No.	
Purchased At			



**BINDTEC CO.,LTD.**

**#1011, 177 Sagimakgol-ro, Jungwon-gu,  
Seongnam-si, Gyeonggi-do, Republic of Korea 13202**

**Tel.: +82-31-734-2868 / Fax: +82-31-734-2869**

**email: [sales@bindtec.kr](mailto:sales@bindtec.kr)**

**<http://www.bindtec.kr>**